

WRONG: The towel is one continuous loop so I may be using a towel someone else has used.

RIGHT: The towel is not a loop but an open ended 40 yard length of cloth. The clean towel is stored in a bin at the bottom of the cabinet. The dirty towel is wound into a compartment at the top of the cabinet. The clean and dirty towel are completely separate. The two never touch.

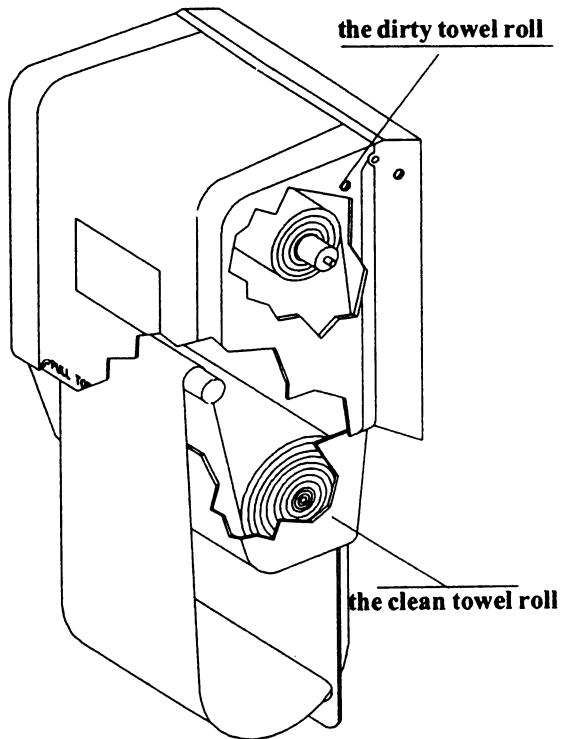

Note: When the towel cabinet is empty, the end of the cloth roll hangs down from the cabinet. It is time for the installation of a clean roll of towel.

1. Blackmore, M.A. and Prisk, E.M. Hand Drying and Hygiene - Public Awareness, & Is Hot Air Hygienic? *The Home Economist*, 1984

2. Hogg, H.S. Investigation into the Cleansing Efficiency of Paper and Cabinet Towels, Courtaulds Research, 1986

3. "Experimental Tests on Towel Hygiene" Mrs. Ehrengard Weiler at the Institute of Hygiene at the University of Heidelberg on the occasion of the 3rd Convention for Bekleidungsmedizin of the German Medical Information Service in Baden-Baden, October 8-9, 1962.

4. Pouw, H.S., Wessels, and van der Zee, H. Research Report B86-0944. Investigation of a Roller Towel Machine Challenged with a Heavy Bacterial Contamination, Division for Nutrition and Food Research, 1986.

5. Wetzler, T.F., Quan, T.J. and Schatzle, K. Critical Analysis of the Microflora of Toweling. *American Journal of Public Health*, 1971.

Cloth Roll Towel ...

- » Is up to four times more absorbent than paper.
- » Completes the cleaning process by removing more germs from hands than hot air and paper towels.

**The clear, clean choice
for hand drying is a
cloth towel.**

DARMAN
MANUFACTURING COMPANY, INC.

© Copyright 1992
DARMAN MFG. CO. INC.

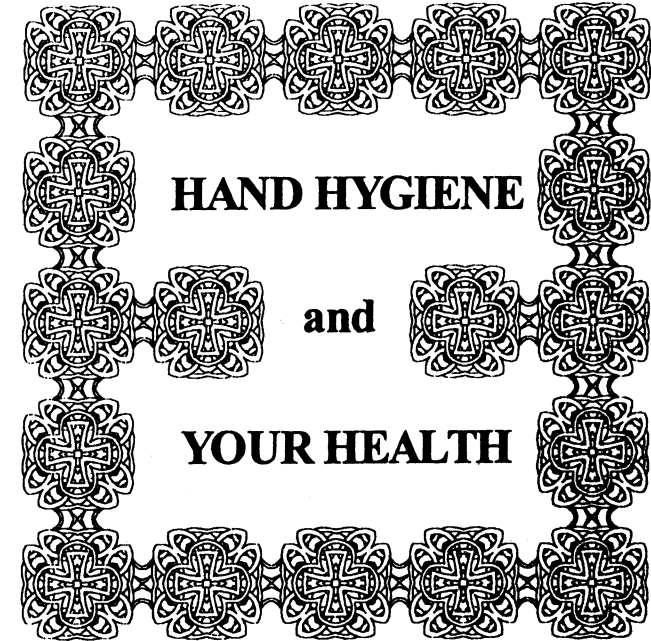

Cleanliness is the cornerstone of good health, and with disease on the rise, personal hygiene is more important than ever.

The Center for Disease Control in Atlanta has stated that hand hygiene is the most important single way to prevent the spread of infection.

We wash, rinse and dry our hands so often that an important element of hand care may be overlooked. Washing is only half the job.

Washing and rinsing do not remove all dirt and bacteria from the skin. It is drying that completes the job.

COMMON MISCONCEPTIONS ABOUT CLOTHROLL TOWELS

It is not a matter of more energetic scrubbing. Some bacteria always escapes the wash and rinse. This remaining bacteria is the reason it is important to know the best hand drying method.

The three hand drying methods available in public situations are the hot air dryer, paper towels or cloth roll towels.

Scientific studies show that cloth roll towel removes significantly more bacteria than either paper towels or the hot air from a blow dryer.¹ The soft cotton fabric in cloth roll towel is more comfortable, more absorbent, and more efficient in removing bacteria than paper towel.²

WRONG: To get a clean section of cloth towel to dry my hands I must touch the dirty part of the towel.

RIGHT: There is a clean strip of cloth towel 2 to 3 inches from the top edge. Just grab this clean portion and pull down. You now have a clean towel without having touched the soiled towel.

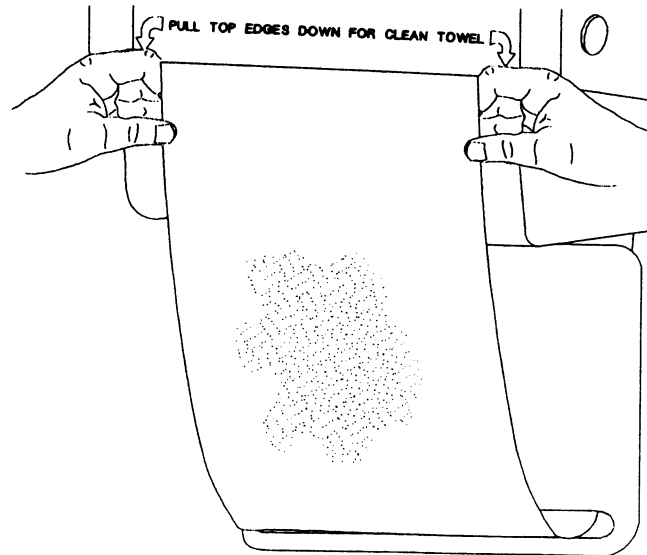

Used properly (as shown) you will never come in contact with germs from the prior user.³

WRONG: Germs from prior users "move" to the clean part of the towel.

RIGHT: Research has shown that the germs don't move from the dirty to the clean part of the towel.⁴

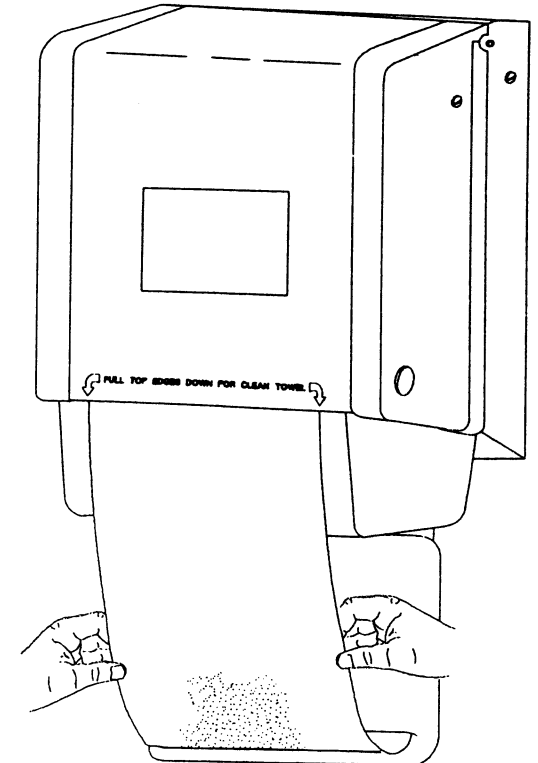

Research has shown that laundering the towel kills germs. The clean towel is sanitary.⁵

Comparison of hygienic efficiency of hand drying methods

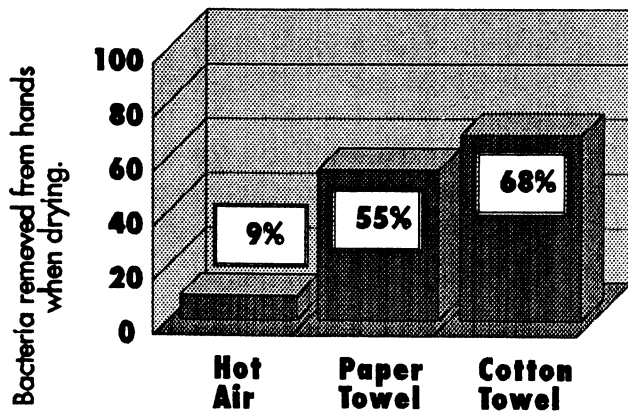

Source: M.A. Blackmore and E.M. Prisk, The Home Economist, 1984